

Tatiana KUGAEVSKA

Vladimir SHULGIN

Poltava National Technical Yuri Kondratyuk University, Ukraine

PROCESSES OF MASS TRANSFER IN PERIOD LOADING CHAMBER OF CONCRETE PRODUCTS

Abstract: *Proposed investigate variety heat treatment of concrete and reinforced concrete products using only the heat released during cement hydration. The peculiarity of this variety consists in that the surface of products not hydro-insulated. Accordingly, in the thermal chamber than heat exchange processes the processes of mass transfer between the surface products and the air chamber. In the quantitative analysis of these processes is necessary to know number the initial factors, among them – the moisture content of the air chamber.*

The processes of heat and mass transfer between the surface of concrete and reinforced concrete products and air chambers begin already during loading them into the camera. During the loading of products is air combined with air workshop. Therefore for each case must quantify the impact of mass transfer processes on the initial moisture content of the air chamber.

Considered dependence that characterizes the process of evaporation of moisture from the surface of concrete products. Results of calculating the amount of moisture that evaporates from the surface of concrete paving slabs during selected period of time.

In further research is necessary to analyze the processes of heat and mass transfer in the chamber, where the heat treatment of concrete or reinforced concrete products (non-hydro-insulated) is using only the heat released during cement hydration.

Keywords: *concrete and ferroconcrete products, mass transfer processes, hydration of cement.*

Introduction

Implementation of thermal treatment of concrete and reinforced concrete products using only the heat released during cement hydration needs a number of experimental and computational studies [1-4].

Review of recent sources of research and publications

The interaction of cement with water heat released [2, 4-9]. In the patent [1] proposed to carry out heat treatment of concrete and reinforced concrete products using only the heat released during cement hydration. In the patent notes that the products before loading into the heat-insulating chamber covered with polyethylene film (or other hydro-insulation material) to store in products moisture needed for hydration of cement. However, it is necessary to investigate the way heat treatment of concrete and reinforced concrete products using only the heat released by the interaction of cement with water, in which the surface of products not hydro-insulated. In this case, will be mass transfer between the surface of products and the environment of the camera.

In the book [10] shows the processes of heat and mass transfer during evaporation and condensation of liquid. In the book [11] show the processes of heat and mass transfer in steam treatment concrete and reinforced concrete products using steam.

Determination unsolved before parts problems

The processes of heat and mass transfer between the surface of concrete and reinforced concrete products and air chambers begin already during loading them into the camera. It is advisable to conduct a quantitative analysis of these processes.

Formulation of the problem

Purpose of the article – the analysis of mass transfer processes between the surface of concrete products and air thermal chamber when loading them into the camera.

The basic material and results

The processes of mass transfer between the surface of concrete and ferroconcrete products and air thermal chamber during loading them into the camera. These processes are interconnected with the processes of heat transfer in the chamber.

There are three main cases the direction of heat flow and flow of water vapor during this period. First case:

- temperature of concrete and ferroconcrete products t_c lower than the air temperature workshop t_w and temperature t_c constructions enclosing chamber for thermal treatment of concrete products;
- temperature of concrete products t_c higher than the temperature «dew point» t_{PDP} .

The direction of heat flow in the chamber at this time is reflected in figure 1. In this case, the partial pressure of water vapor the air chamber or lower or higher than the partial pressure of water vapor near the surface of the concrete mix. Directions mass flow depends on the ratio between the partial pressure.

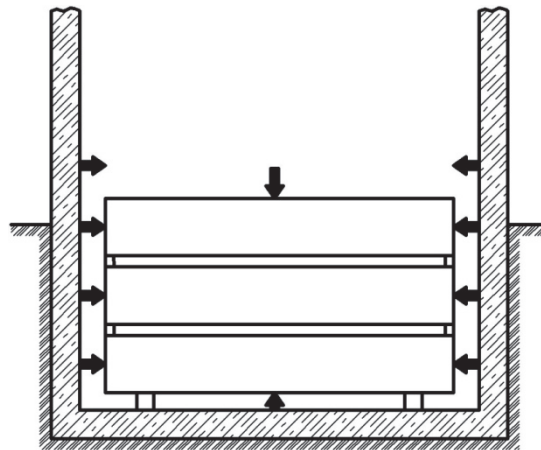

FIGURE 1. Scheme of heat flow in the chamber during loading of products (the first case)

The second case:

- temperature of concrete and reinforced concrete products t_c higher than the air temperature workshop t_w and temperature t_c constructions enclosing chamber for thermal treatment of concrete products;
- air temperature chamber is higher than the temperature "dew point" t_{DP} .

The direction of heat flow in the chamber at this time is reflected in figure 2. In this case, the partial pressure of water vapor the air chamber lower than the partial pressure of water vapor near the

surface of the concrete mix. Accordingly, will occur evaporation of moisture from the surface of products.

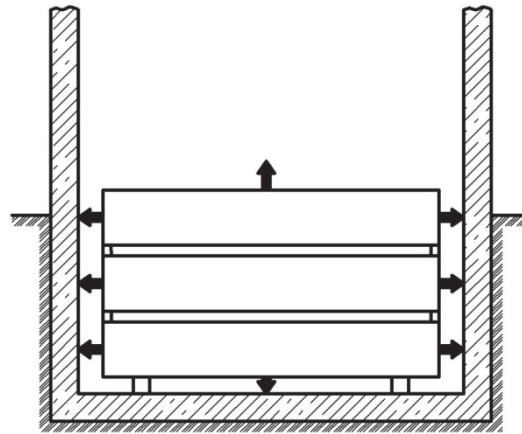

FIGURE 2. Scheme of heat flow in the chamber during loading of products (second case)

The third case: $t_c = t_w > t_{DP}$

Consider the cases when the partial pressure of water vapor near the surface formed concrete products higher than the partial pressure of water vapor in the air chamber. The surface of the concrete products during their formation and stay in the chamber while loading – moisture. So take approximately that evaporation of moisture from the surface of the product in this period is similar to evaporation of moisture from the surface of water.

The amount of moisture W , that evaporates from the surface of the product per unit of time, kg/s, determined by the formulas given in particular the book [10]:

$$W = \beta' \cdot (P_{SC} - P_{AIR}) \cdot (101325 / P_B) \cdot F \quad (1)$$

$$W = \beta \cdot (C_{SC} - C_{AIR}) \cdot (101325 / P_B) \cdot F \quad (2)$$

the amount of moisture $W_{\Delta\tau}$, that evaporates from the surface of the product for a certain period of time $\Delta\tau$, kg, calculated by the formulas:

$$W_{\Delta\tau} = \beta' \cdot (P_{SC} - P_{AIR}) \cdot (101325 / P_B) \cdot F \cdot \Delta\tau \quad (3)$$

$$W_{\Delta\tau} = \beta \cdot (C_{SC} - C_{AIR}) \cdot (101325 / P_B) \cdot F \cdot \Delta\tau \quad (4)$$

where:

β' – mass transfer coefficient (mass returns), referred to the difference of partial pressures ($P_{SC} - P_{AIR}$), $\text{kg}/(\text{m}^2 \cdot \text{s} \cdot \text{P})$;

β – mass transfer coefficient (mass returns), referred to the difference of water vapor concentration ($C_{SC} - C_{AIR}$), m/s ;

P_{SC} – the partial pressure of water vapor near the surface of the concrete product, P;

P_{AIR} – the partial pressure of water vapor in the air chamber, P;

C_{SC} – the concentration of water vapor near the surface of the concrete product, kg/m^3 ;

C_{AIR} – the concentration of water vapor in the air chamber, kg/m^3 ;

P_B – barometric pressure, P;

F – area open surface of concrete products, m^2 .

The concentration of water vapor in the air chamber is calculated by dependence

$$c_{AIR} = \frac{P_{AIR} / 133.322}{3.463(273 + t_{AIR})} \quad (5)$$

the concentration of water vapor in the air near the surface of the product is calculated by dependence

$$c_{SC} = \frac{P_{SC} / 133.322}{3.463(273 + t_{SC})} \quad (6)$$

where:

t_{AIR} – air temperature chamber, °C;

t_{SC} – the surface temperature of the concrete product, °C.

Mass transfer coefficient β , m/s, is equal to

$$\beta = Nu' \frac{D}{L} \quad (7)$$

where:

Nu' – diffusion Nusselt number;

D – the diffusion coefficient, m²/s;

L – the determining size, m.

For water vapor the diffusion coefficient, m²/s, calculated by the formula given the book [10]

$$D = 0.0754 \cdot \left(\frac{T}{273} \right)^{1.89} \cdot \frac{101325}{P_B} \quad [\text{m}^2/\text{h}] \quad (8)$$

$$D = 0.0754 \cdot \left(\frac{T}{273} \right)^{1.89} \cdot \frac{101325}{P_B} \cdot \frac{1}{3600} \quad [\text{m}^2/\text{s}] \quad (9)$$

$$T = t + 273 \quad (10)$$

$$t = 0.5 \cdot (t_{AIR} + t_{SC}) \quad (11)$$

where:

T – absolute average air temperature is, K;

t – average air temperature is, °C.

Diffusion Nusselt number can be determined by the formula given in the book [10]:

$$Nu' = 0.66 \cdot (Ar \cdot Pr')^{0.26} \quad (12)$$

(at $Ar \cdot Pr' = 3 \cdot 10^6 - 2 \cdot 10^8$)

where:

Ar – Archimedes criterion;

Pr' – diffusion Prandtl number.

Diffusion Prandtl number is equal to

$$Pr' = \frac{\nu}{D} \quad (13)$$

where:

Pr' – diffusion Prandtl number;

ν – kinematic coefficient of viscosity of air at an average temperature of air t , m²/s.

Archimedes criterion is equal to

$$Ar = \frac{L^3 g}{\nu^2} \cdot \frac{\Delta\rho}{\rho} \quad (14)$$

$$L = \sqrt{F} \quad (15)$$

where:

L – the determining size, m;

F – area open surface of concrete products, m²;

g – acceleration of gravity, m/s²;

$\Delta\rho$ – air density difference, kg/m³.

The density of the air chamber, kg/m³, calculated by dependence

$$\rho_{AIR} = 1.293 \cdot \frac{273}{T_{AIR}} \cdot \left(\frac{101325}{P_B} - 0.378 \cdot \frac{P_{AIR}}{101325} \right) \quad (16)$$

air density near the surface of the wet concrete mixture, kg/m³, calculated by dependence

$$\rho_{SC} = 1.293 \cdot \frac{273}{T_{SC}} \cdot \left(\frac{101325}{P_B} - 0.378 \cdot \frac{P_{SC}}{101325} \right) \quad (17)$$

where:

P_{AIR} – the partial pressure of water vapor in the air equipment, P;

P_{SC} – the partial pressure of water vapor near the surface of the concrete product, P.

In the table 1 shows examples of calculating the amount of moisture that evaporates from the surface of concrete paving slabs in the first 15 minutes she was in the chamber

TABLE 1. Number of moisture that evaporates from the surface of concrete paving slabs

$t_{AIR}, ^\circ\text{C}$	$\varphi_{AIR}, \%$	$T_{SC}, ^\circ\text{C}$	$W, \text{kg/s}$	$W_{\Delta\tau}, \text{kg}$	$\Delta\tau, \text{h (s)}$	F, m^2
20	65	18	$4.52 \cdot 10^{-6}$	0.0041	0.25 (900)	0.5
20	65	20	$5.91 \cdot 10^{-6}$	0.0053	0.25 (900)	0.5
20	55	20	$8.12 \cdot 10^{-6}$	0.0073	0.25 (900)	0.5
20	65	22	$1.12 \cdot 10^{-5}$	0.0101	0.25 (900)	0.5
25	65	25	$8.67 \cdot 10^{-6}$	0.0078	0.25 (900)	0.5
25	55	25	$1.19 \cdot 10^{-5}$	0.0107	0.25 (900)	0.5

Evaporated from concrete or reinforced concrete products water vapor increases the moisture content of the air chamber. During loading products air chamber combined with air workshop. Therefore for each case must quantify influence of processes mass transfer on moisture content of the air chamber. This moisture content is one of the primary parameters in the analysis of heat and mass transfer in the chamber, where the acceleration of hardening concrete products (non-hydro-insulated) occurs without the use of coolant.

Conclusions

Considered the processes of mass transfer during the loading of concrete or reinforced concrete products in the thermal camera.

In further research is necessary to analyze the processes of heat and mass transfer in the chamber, where the heat treatment of concrete or reinforced concrete products (non-hydro-insulated) is using only the heat released during cement hydration.

References

- [1] Pat. № 90487. Ukraine. MPC C04B 40/02 (2006.01). The method of heat treatment of concrete and concrete products / T.S. Kugaevska, V.V. Shulgin; the applicant and owner of Poltava National Technical Yuri Kondratyuk University.; appl. 13.01. 2014; publ. 26.05.2014, bul. № 10.
- [2] Kugaevskaya T.S.: *Development of prediction method of concrete products temperature changes under their curing*. T.S. Kugaevskaya, V.V. Shulgin, Conference reports materials «Problems of energy saving and nature use 2013», Budapest 2014, pp. 46-52.
- [3] Kugaevska T.S.: *Definitions consumption of heat on heating designs chambers for thermal treatment concrete products*. T.S. Kugaevska, V.V. Shulgin, Collection of scientific articles «Energy, energy saving and rational nature use», Kazimierz Pulaski University of Technology and Humanities in Radom, № 1 (4) Radom 2015, Poland 2015, pp. 42-45.
- [4] Kugaevska T.: *Development of methodology forecasting of intensity solidification concrete products in the alternative methods of heat treatment*, Energy, energy saving and rational nature use, Oradea University Press, 2015, pp. 4-52.
- [5] Volzhenskij A.V.: *The mineral binders substances*. A.V. Volzhenskij. M: Strojizdat 1986, 464 p.
- [6] Mchedlov-Petrosjan O.P.: *Heat release of hardening binding substance and concretes*. O.P. Mchedlov-Petrosjan, A.V. Usherov-Marshak, A.M. Urzhenko, M: Strojizdat, 1984, 224 p.
- [7] Lotov V.A.: *Heat generation in the cement-water upon hydration and hardening*. V.A. Lotov, E.A. Sudarev, J.A. Ivanov. Stroitelnye materialy, 2011, No. 11, pp. 35-37.
- [8] *Temperature monitoring hardening cement systems*. A.V. Kabus', N.N. Isaenko, E.A. Moroz. E.V. Ivashhenko, E.B. Voropaeva. Naukovij visnik budivnictva. Issue 65, KNUCA, Kharkiv 2011, pp. 256-263.
- [9] Livsha R.J.: *Evaluation exotherm at an early stage hardening cement-concrete coatings* [Electronic resource]. R.J. Livsha, L.O. Karasova. Access mode: <http://ena.lp.edu.ua:8080/bitstream/ntb/7655/1/25.pdf>.
- [10] Nesterenko A.V.: *Basics of thermodynamic calculations of ventilation and air conditioning*. A.V. Nesterenko. M: Vyssh. shkola, 1971, 460 p.
- [11] Marjamov N.B.: *Heat treatment of products in the factories of precast reinforced concrete*. N.B. Marjamov, M: Publ. liter. for the construction, 1970, 272 p.